

Standardtype

Ventil in Ruhestellung geschlossen - (NC). Bei erregtem Magnet baut sich die Druckdifferenz von der Sekundärseite des Kolbens über die Servobohrung ab. Die wirksame Druckdifferenz (Δp) hebt den Kolben vom Ventilsitz ab. Der angegebene Mindestdruck muss als Druckdifferenz (Δp) immer vorhanden sein.

Standard type

Valve non-energised closed by spring power - NC. When energised, the pressure decomposes on the secondary side of the piston via the pilot hole. Then the pressure differential (Δp) lifts the piston from the seat (orifice). The stated minimum pressure must always be as pressure differential (Δp).



Steuerungsart: Type of control:	servogesteuert pilot operated	Metall. Innenteile: Metallic internals:	Messing und Edelstahl 1.4104 Brass and stainless steel (AISI 430F)
Konstruktion: Construction:	Kolbensitzventil Piston design	Dichtung: Seal:	NBR NBR
Anschluss: Connection:	Flansch DN15-DN300 Flanges DN15-DN300	Einbaulage: Installation:	beliebig, vorzugsweise mit stehendem Magneten ab DN65 nur mit stehendem Magneten actuator in any position preferable upright from DN65 actuator only in upright position
Druck: Pressure:	1-40 bar (s. Tabelle) 1-40 bar (see table)		
Durchflussmedium: Medium:	neutrale, gasförmige u. flüssige Medien neutral, gaseous and liquid media	Anschlussspannung: Supply voltage:	AC: 24,42,110,230V 50/60 Hz DC: 24,110,205V=
Viskosität: Viscosity:	22mm ² /s 22mm ² /s	Spannungstoleranz: Voltage tolerance:	+10% / -10% +10% / -10%
Mediumtemperatur: Medium temperature:	-10 bis +80°C -10 up to +80°C	Leistungsaufnahme: Power-consumption:	1032=11 Watt 0032=24/15 VA 1012=18,5 Watt 0012=43/24 VA 1802/3802 = 24 Watt 1322/3322 = 30 Watt 4242/5242 = 46 Watt 4272/5272 = 100 Watt
Umgebungstemperatur: Ambient temperature:	+35°C +35°C		
Ventilgehäuse: Body material:	../03../.. = Sphäroguss GGG-40.3 / Spheroidal graphite iron ../04../.. = Grauguss GG-25 / Cast iron ../05../.. = Stahlguss GS-C25 / Cast steel ../08../.. = Edelstahl 1.4581 Stainless steel (AISI 316Ti) ab DN65 Edelstahl 1.4408/ up to DN65 Stainless steel (AISI 316L)	Schutzart: Enclosure:	IP65 nach DIN 40050 IP65 according to DIN 40050
		Einschaltdauer: Operating factor:	100% ED-VDE 0580 100% ED-VDE 0580
		Kabelanschluss: Electric connection:	Gerätestecker DIN 43650 / Klemmkasten DIN 43650 - plug / terminal box

Die Kv-Werte in der Tabelle gelten jeweils für das größte angegebene Magnetsystem!*
In each case, the flow-rate in the table are for the biggest mentioned solenoid system!*

DN	Sitz Orifice Ømm	Kv-Wert Flow-rate m ³ /h	Standardtype Standard type	max. Druck bei Magnettype max. pressure regarding solenoid type					
				.032	.012	.802	.322	.242	.272
15	15	5,0	.2501/0.01/....	1-16	1-40*	-	-	-	-
20	20	11,0	.2502/0.01/....	1-16	1-40*	-	-	-	-
25	25	13,0	.2503/0.01/....	1-16	1-40*	-	-	-	-
32	32	28,0	.2504/0.01/....	1-16	1-40*	-	-	-	-
40	40	30,0	.2505/0.01/....	1-16	1-40*	-	-	-	-
50	50	46,0	.2506/0.01/....	1-16	1-40*	-	-	-	-
65	65	75,0	.2507/0.01/....	-	-	1-40*	-	-	-
80	80	97,0	.2508/0.01/....	-	-	1-16	1-40*	-	-
100	100	143,0	.2509/0.01/....	-	-	1-16	1-40*	-	-
125	125	240,0	.2510/0.01/....	-	-	-	2-16	2-40*	-
150	150	370,0	.2511/0.01/....	-	-	-	2-16	2-40*	-
200	200	625,0	.2512/0.01/....	-	-	-	-	2-16	2-40*
250	250	950,0	.2513/0.01/....	-	-	-	-	-	2-40*
300	300	1400,0	.2514/0.01/....	-	-	-	-	-	2-40*

Maßzeichnung Standardausführung
Dimensional drawing of standard type

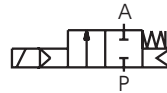
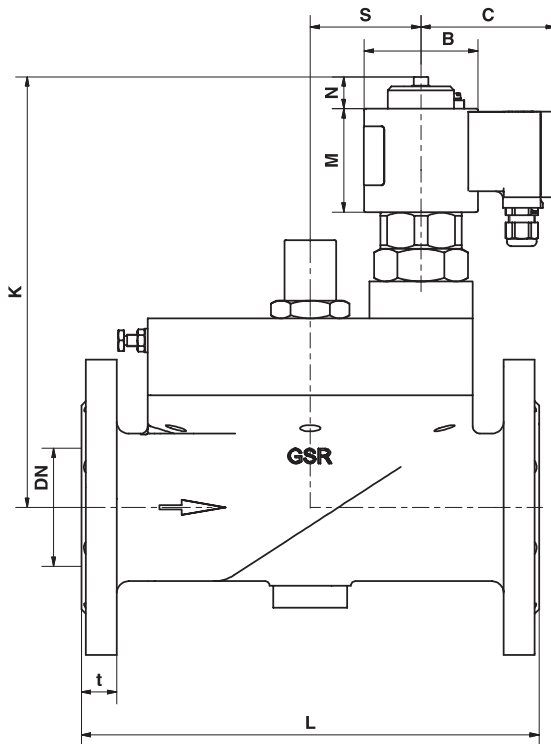

Schaltfunktion/Function:
in Ruhstellung gesperrt - NC.
normally closed - NC.

Anschlussplan / Connection diagram

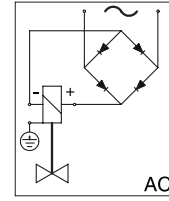
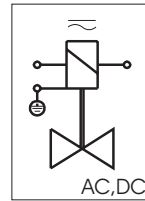

Für Wechsel- und Gleichspannung.
For AC and DC.

Mit vorgeschaltetem Gleichrichter
für Wechselspannung.
With rectifier for AC connection.

Erdung oder Schutzschaltung nach Vorschrift des zuständigen EVU.
Grounding or earthing of the protective circuit in accordance with regulations of the responsible electric supply company.

Absicherung entsprechend der Stromaufnahme vorsehen.
Appropriate protection according to the power-consumption.

PN16-Flansche nach DIN 2533
PN16-flanges according to DIN 2533

PN40-Flansche nach DIN 2545
PN40-flanges according to DIN 2545

Magn. Solen.	.032/.012						.802			.322				.242			.272		
Type	2501	2502	2503	2504	2505	2506	2507	2508	2509	2508	2509	2510	2511	2510	2511	2512	2512	2513	2514
DN	15	20	25	32	40	50	65	80	100	80	100	125	150	125	150	200	200	250	300
B	35x32	35x32	35x32	35x32	35x32	35x32	Ø49	Ø49	Ø49	Ø63	Ø63	Ø63	Ø63	Ø77	Ø77	Ø77	Ø105	Ø105	Ø105
C	58	58	58	58	58	58	66	66	66	76	76	76	76	82	82	82	95	95	95
H	173	184	189	221	226	241	283	330	340	345	355	430	475	455	500	540	570	602,5	640
K	125	131	131	151	151	158	190	230	230	245	245	305	335	330	360	370	400	400	410
L	130	150	160	180	200	230	290	310	350	310	350	400	480	400	480	600	600	730	850
M	40	40	40	40	40	40	55	55	55	59	59	59	59	70	70	70	90	90	90
N	10	10	10	10	10	10	10	10	10	16	16	16	16	20	20	20	25	25	25
S	20	20	20	39	39	50	65	85	90	85	90	-	-	-	-	-	-	-	-
t	16	18	18	18	18	20	20	20	22	20	22	24	26	24	26	26	26	34	38
Pg	11	11	11	11	11	11	11	11	11	11	11	11	11	11	11	11	11	11	11
kg	3,5	3,9	4,3	9,1	9,8	12,6	31,0	39,0	59,0	44,0	68,0	95,0	103,0	97,5	105,5	119,0	122,0	172,0	242,0

Alle Angaben sind freibleibend und unverbindlich / All technical specifications are without obligation!

Weitere Ventilausführungen

/

Valve options

Stromlos geöffnet = NO
Non energised open = NO

Handbetätigung = HA
Manual override = HA

Dichtung = FKM, EPDM, PTFE
Sealing = FKM, EPDM, PTFE

Grundmengeneinstellung = GM
Base volume adjustment = GM

Andere Durchflussmedien und Viskositäten
Varying medium and viscosity ranges

Regulierbare Schließdämpfung = SR
Variable close muting = SR

Abweichende Temperaturen und Drücke
Varying temperature and pressure ranges

Für Sauerstoffanwendungen = OF
For oxygen applications = OF

Stellungsanzeiger (Endschalter ab DN20) = EH
Position indicator (reed contact from DN20) = EH

Buntmetallfrei = BF
Free of brass and bronze = BF

Ex-Schutz = Ex II 2G EEx d II c T4, T5 oder T6
Explosion proof = Ex II 2G EEx d II c T4, T5 or T6

Temperaturausführung bis +180°C = TH
Design for high temperature up to +180°C = TH

Stückliste - Parts list

- K1.1 Armatur / Valve body
- K1.2 Sitz / Seat
- K2.1 Deckel / Bonnet
- *K3.1 Kolben / Piston
- *K3.2 Dichtung / Seal
- *K3.3 Scheibe / Disk
- *K3.4 Senkschraube / Counter-sunk bolt
- *K3.5 Nutring / U-ring
- *K3.6 O-Ring / O-ring
- *K3.7 O-Ring / O-ring
- *K3.9 Feder / Spring
- K3.10 Zylinderschraube / Cylinder screw
- K3.11 Federring / Spring washer
- K3.12 Sitzdüse / Nozzle
- K5.1 Magnethülse / Solenoid tube
- K5.4 Scheibe / Disk
- K5.5 Mutter / Nut
- K6.1 Magnet / Solenoid
- K7.1 Gerätestecker / Plug

* = Bestandteil des Ersatzteilpäckchens
(je nach Ausführung freibleibend)
* = Parts of the service-set
(these specifications are without obligation)

Baureihe / Type 2501-2503

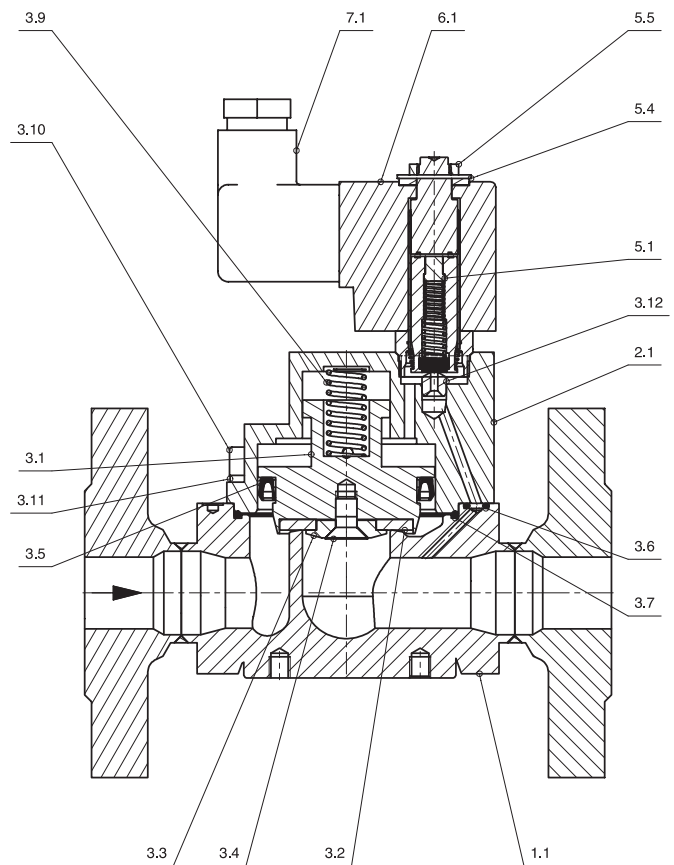

Regulierbare Schließdämpfung - SR (ab DN32 serienmäßig)
Variable close muting - SR (from DN32 standard)

Schraube nach rechts drehen: Ventil schließt langsamer
Screw to the right site: Valve closes slower
Schraube nach links drehen: Ventil schließt schneller
Screw to the left site: Valve closes faster

Stückliste - Parts list

- K1.1 Armatur / Valve body
- K1.2 Sitz / Seat
- K2.1 Deckel / Bonnet
- *K3.1 Kolben / Piston
- *K3.2 Dichtung / Sealing
- *K3.3 Führung / Guidance
- *K3.4 Scheibe / Disk
- K3.5 Verschraubung / Screw joint
- *K3.6 Vorsteuerspindel / Pilot spindle
- *K3.7 Dichtung / Sealing
- K3.8 Dämpfungsschraube / Damping screw
- K3.9 Scheibe / Disk
- *K3.10 O-Ring / O-ring
- *K3.12 O-Ring / O-ring
- *K3.14 O-Ring / O-ring
- *K3.15 O-Ring / O-ring
- K3.16 Verschraubung / Screw joint
- K3.17 Mutter / Nut
- *K3.19 Feder / Spring
- *K3.20 Zylinderschraube / Cylinder screw
- *K3.23 Feder / Spring
- K3.26 Verschraubung / Screw joint
- *K3.27 O-Ring / O-ring
- K5.1 Magnethülse / Solenoid tube
- K6.1 Magnet / Solenoid
- K7.1 Klemmkasten / Terminal box

Baureihe / Type 2504-2509

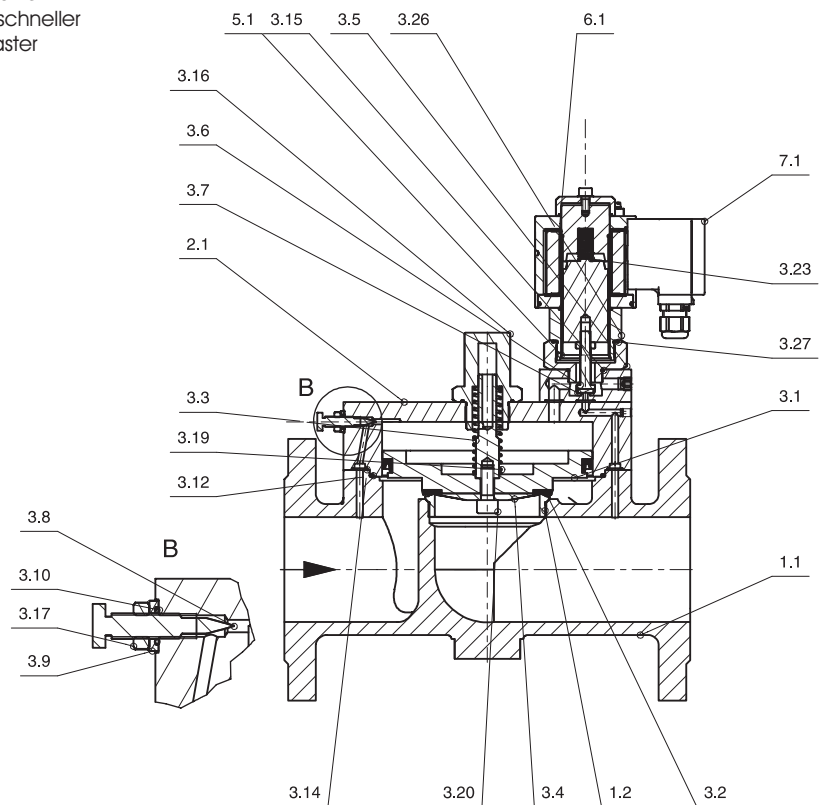

Handbetätigung - HA bei Magnet .032/.012
 Manual override - HA for solenoid .032/.012

Ventiloptionen / Optional extras

- K2.1 Deckel / Bonnet
- K3.62 Spindel / Spindle
- K3.65 O-Ring / O-ring

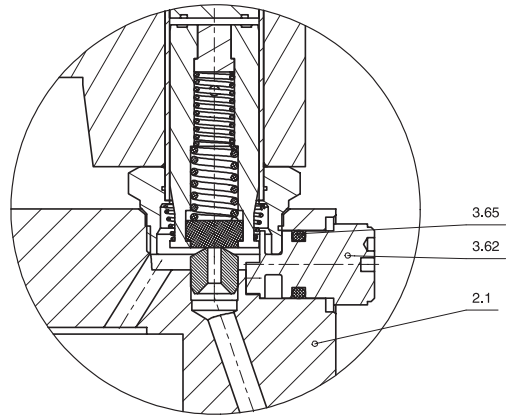

Stellungsanzeiger - EH (ab DN20)
 Position indicator - EH (from DN20)

- K3.75 Zwischenverschraubung / Screw joint
- K3.76 Spindel / Spindle
- K3.77 Kerbstift / Grooved pin
- K3.79 O-Ring / O-ring
- K3.82 Senkschraube / Screw
- K3.83 Permanentmagnet / Permanent magnet
- K3.84 Klemmring / Clamp ring
- K3.85 Verschraubung / Screw joint
- K3.86 Endschalter / Position indicator

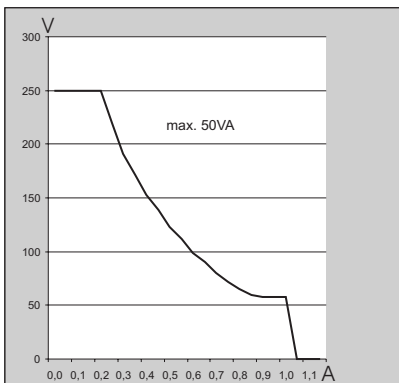
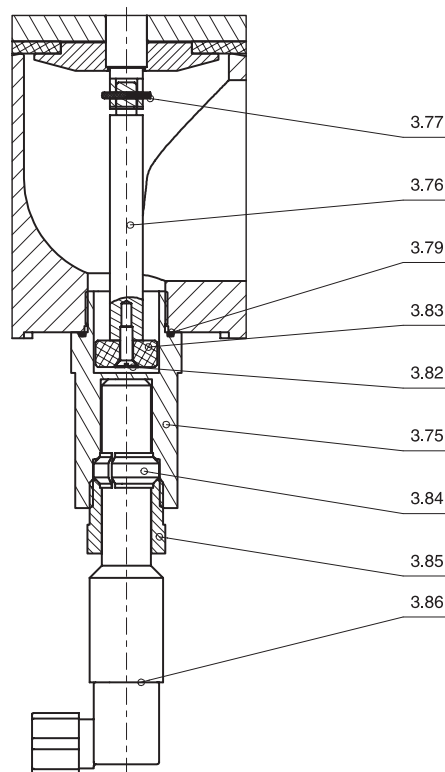

Schaltleistungsdiagramm
 Braking capacity diagram

Anschlussplan
 Connection plan

Endschalter / Position indicator

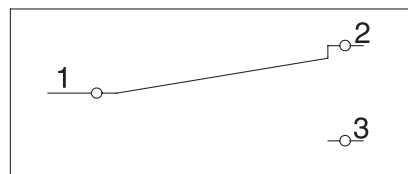

GSR Ventiltechnik GmbH & Co. KG
 Postfach 2060 • D-32595 Vlotho • Im Meisenfeld 1 • D-32602 Vlotho
 Telefon +49 5228 779-0 • Telefax +49 5228 779-190
 E-mail: info@ventiltechnik.de www.ventiltechnik.de