

Standardtype

Ventil in Ruhestellung geschlossen - (NC). Der erregte Magnet öffnet eine Vorsteuerbohrung und hebt direkt oder unterstützt von der Druckdifferenz den Kolben vom Hauptsitz. Das Ventil schließt durch Federkraft.

Standard type

Valve non-energised closed - (NC). When energised, the solenoid lifts the pilot chamber and the valve will open directly or supported by the pressure differential of the flow medium. The valve closes by spring power.



Steuerungsart: Type of control:	zwangsgesteuert force pilot operated	metall. Innenteile: metallic internals:	Messing und Edelstahl 1.4104 Brass and stainless steel(AISI430F)
Konstruktion: Construction:	Kolbensitzventil Piston design	Dichtung: Sealing:	PTFE PTFE
Anschluß: Connection:	G1/4-G3, DIN ISO 228 G1/4-G3, DIN ISO 228	Einbaulage: Installation:	Nur mit stehendem Magneten Actuator only in upright position
Druck: Pressure:	0-40 bar (s. Tabelle) 0-40 bar (see table)	Anschlußspannung: Supply voltage:	AC: 24,110,230V 50Hz DC: 24,110,205V=
Durchflußmedium: Medium:	neutrale, gasförmige u. flüssige Medien neutral, gaseous and liquid media	Spannungstoleranz: Voltage tolerance:	+5% / -10% +5% / -10%
Viskosität: Viscosity:	50mm ² /s 50mm ² /s	Leistungsaufnahme: Power-consumption:	T322 = 21 Watt T242 = 26 Watt T272 = 60 Watt T352 = 80 Watt
Mediumtemperatur: Medium temperature:	-10 bis +180°C (Option -EL +200°C) -10 up to +180°C (option -EL +200°C)	Schutzart: Protection class:	IP65 nach DIN 40050 IP65 according to DIN 40050
Umgebungstemperatur: Ambient temperature:	+35°C +35°C	Einschaltdauer: Duty factor:	100% ED-VDE 0580 100% ED-VDE 0580
Ventilgehäuse: Body material:	../10../.. = Messing / Brass ../08../.. = Edelstahl 1.4581 / Stainless steel (AISI 316 Ti)	Kabelanschluß: Cable connection:	Klemmkasten Terminal box

TH = Temperatureausführung +180°C - Magnetspule wird über einen separaten Gleichrichter betrieben.

TH = High temperature design up to +180°C - solenoid with external rectifier.

EL = Temperatureausführung +200°C - Magnetspule wird über eine separate Schaltelektronik betrieben.

EL = Electric device for higher pick up power for +200°C - solenoid with separate electric device.

EL nur in 230V 50-60Hz möglich, nicht in NO-Ausführung / EL only available in 230V 50-60Hz and not in NO-design.

Die Kv-Werte in der Tabelle gelten jeweils für das größte angegebene Magnetsystem!*

In each case, the flow-rate in the table are for the biggest mentioned solenoid system!*

G	Sitz Orifice Ømm	Kv-Wert Flow-rate m ³ /h	Standardtype Standard type PN40	max. Druck bei Magnettype max. pressure regarding solenoid type			
				T322-TH	T242-TH	T272-TH	T352-TH
1/4	13	1,8	..4921/1004/....	0-10	0-40*	-	-
3/8	13	4,0	..4922/1004/....	0-10	0-40*	-	-
1/2	13	4,5	..4923/1004/....	0-10	0-40*	-	-
3/4	25	11,5	..4924/1004/....	0-6	0-25	0-40*	-
1	25	13,0	..4925/1004/....	0-6	0-25	0-40*	-
5/4	40	29,0	..4926/1004/....	0-6	0-20	0-40*	-
6/4	40	33,0	..4927/1004/....	0-6	0-20	0-40*	-
2	50	49,0	..4928/1004/....	-	0-6	0-25	0-40*
2½	62	58,0	..4929/1004/....	-	-	0-10*	-
3	76	60,0	..4930/1004/....	-	-	0-10*	-

Stückliste - Parts list

- K1.1 Armatur / Valve body
- K2.1 Deckel / Bonnet
- *K3.1 Vorsteuersitz / Pilot seat
- *K3.2 Ventilkolben komplett / Complete valve piston
- *K3.3 Führungsstern / Guiding insert
- *K3.4 Vorsteuerspindel / Pilot spindle
- *K3.5 Ventilteller / Valve head
- *K3.7 Überwurfmutter / Union nut
- *K3.8 Kolben / Piston
- K3.13 Dämpfungsschraube / Damping screw
- K3.14 Scheibe / Disk
- *K3.17 Führungsband / Piston ring
- *K3.18 O-Ring / O-ring
- *K3.20 O-Ring / O-ring
- *K3.21 O-Ring / O-ring
- *K3.22 O-Ring / O-ring
- *K3.23 O-Ring / O-ring
- K3.27 6-kt. Mutter / Hexagon nut
- K3.28 6-kt. Mutter / Hexagon nut
- *K3.33 Feder / Spring
- K5.1 Magnethülse / Solenoid tube
- K5.2 Magnetanker / Solenoid plunger
- K5.4 Druckstück / Pressure piece
- K5.5 O-Ring / O-ring
- K5.6 Scheibe / Disk
- K5.8 Zylinderschraube / Cylinder screw
- K5.9 Scheibe / Disk
- K6.1 Magnetspule / Solenoid
- K7.1 Klemmkasten / Terminal box

* = Bestandteil des Ersatzteilpäckchens
(je nach Ausführung freibleibend)
* = Part of the spare parts set.
(These specifications are without obligation).

Baureihe / Type H4921-H4925

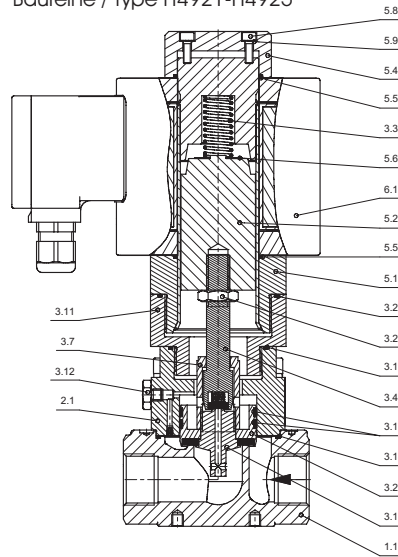

Baureihe / Type E4926-E4928

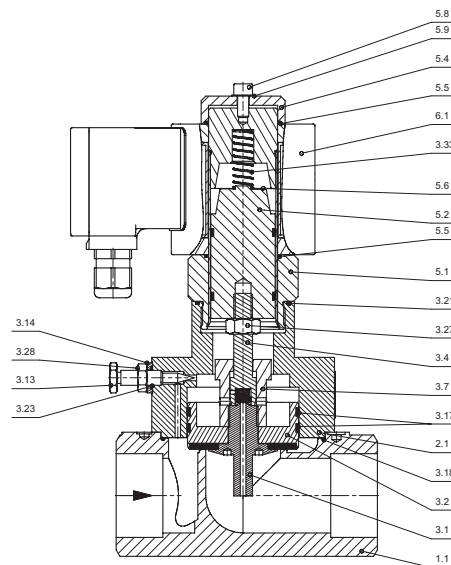

Magnet Solenoid	.702	.322				.242				.272	
Type	4921-4923	4921-4923	4924-4925	4926-4927	4924-4925	4926-4927	4928	4929	4930	4926-4927	4928
G	1/4-1/2	1/4-1/2	3/4-1	5/4-6/4	3/4-1	5/4-6/4	2	2 1/2	3	5/4-6/4	2
A	50	50	70	96	70	96	112	90	105	96	112
B	35x35	Ø63	Ø63	Ø63	Ø77	Ø77	Ø77	Ø77	Ø77	Ø105	Ø105
C	66	76	76	76	82	82	82	82	82	95	95
H	173	200	200	238	225	263	275	275	292	310	290
K	158	185	175	205	200	230	240	205	212	277	255
L	67	67	96	140	96	140	168	175	200	140	168
M	50	59	59	59	70	70	70	70	70	90	90
N	10	16	16	16	20	20	20	20	25	25	25
SW	27	27	41	58	41	58	70	86	100	58	70
t	12	12	16	22	16	22	25	18	20	22	25
Pg	11	11	11	11	11	11	11	11	11	11	11
kg	0,7	1,5	3,5	6,8	4,2	7,5	8,6	9,2	9,5	9,9	11



GSR Ventiltechnik GmbH & Co. KG
 Postfach 2060 • D-32595 Vlotho • Im Meisenfeld 1 • D-32602 Vlotho
 Telefon (05228) 779-0 • Telefax (05228) 779-190
 E-mail: info@ventiltechnik.de http://www.ventiltechnik.de