

MODEL**VG**

RUBBER SLEEVE KNIFE GATE VALVE

The **VG** model knife gate is a bi-directional wafer valve equipped with two metallic covered rubber sleeves designed for use in the handling of abrasive slurries, mainly in industries such as:

- Mining
- Chemical plants
- etc.
- Power plants
- Wastewater treatment

Sizes: DN 50 to DN 900 (larger DN on request)

Working pressure:

DN 50/400	10 bar
DN 450/600	6 bar
DN 700/900	5 bar

Higher pressures and/or diameters on request

Standard Flange connection: DIN PN 10 and ANSI B16.5 (class 150)

Other: (On request)

DIN PN 6

BS "D" and "E"

DIN PN 16

ANSI 125

DIN PN 25

Others on request

Directives: DIR 98/37/CE (MACHINES)
 DIR 97/23/CE (PED) Fluid: Group 1(b), 2 (Cat. I, mod. A)
 DIR 94/9/CE (ATEX)

All ORBINOX valves are tested prior to shipping.

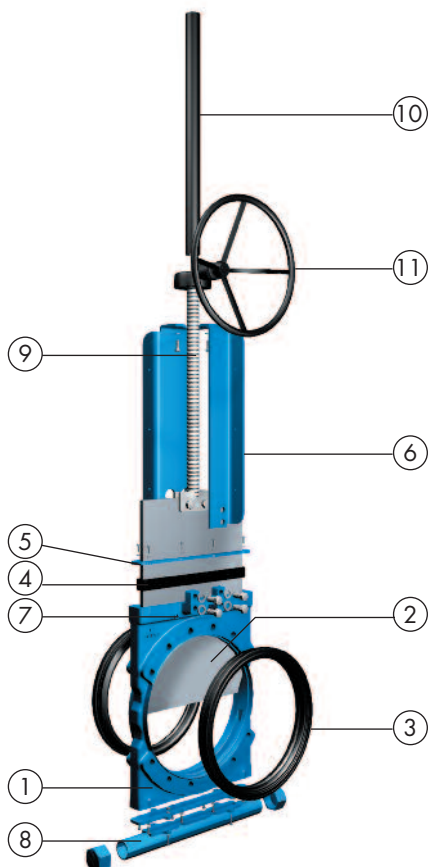

STANDARD PARTS LIST

Part :	Materials:
1- Body	Ductile iron A536 (60-40-18) / 0.7040 / GJS 400
2- Gate	AISI 304 (1.4301)
3- Sleeves	Natural rubber
4- Packing	EPDM
5- Gland Follower	A570 GR.40 / 1.0044 Epoxy coated
6- Yoke	A570 GR.40 / 1.0044 Epoxy coated
7- Grease Nipple	Zinc coated carbon-steel
8- Splash guard	A570 GR.40 / 1.0044 Epoxy coated
	(optional)
9- Stem	AISI 430 / 1.4016
10- Stem protector	A570 GR.40 / 1.0044 Epoxy coated
11- Bevel Gear	

DESIGN FEATURES

BODY

Wafer style cast **monoblock**, for installation between flanges, with reinforced ribs in larger diameters, providing the body with extra strength. Internal body design allows the gate to be fully guided. It is equipped with two machined lateral mouths where the sleeves fit perfectly. The grease nipples allow the gate to be lubricated, thus enhancing its capacity to slide between the sleeves. Additionally, the design allows draining through the lower part, where a cover or a bottom splash guard can be installed.

GATE

Made of **stainless steel**, polished on both sides, and of rectangular shape, the gate is machined to an edge. As well as reducing friction and damage to the seats, this design allows it to cut perfectly through the fluid. The material can be changed upon request, thus allowing greater working pressures.

RUBBER SLEEVES

The seat is made up of two highly resistant, long-lasting sleeves, made of natural rubber with a metallic core. Its highly research and patented hollow design allows for maximum flexibility on passing through the gate, minimising the effort necessary for its operation.

The two sleeves are in permanent contact with each other, so that there is total flow. There are no seat cavities which may cause build-up, and the fluid does not come into contact with the metallic parts of the valve. This design allows for easy replacement of damaged sleeves. (See available materials on page VG-5).

PACKING:

Made of EPDM, it eliminates possible leaks to the exterior as well as minimising the maintenance needs of traditional packings. In combination with the grease nipples, it guarantees an optimal functioning of the gate.

STEM:

Made of **stainless steel**, which provides it with a high resistance to corrosion and a long life. Besides making the valve safe, the **stem protector** also protects it against dirt.

EXCHANGEABILITY OF THE ACTUATORS:

All the actuators are easily interchangeable with one another.

ACTUATOR SUPPORT or YOKE:

Made of steel (stainless steel available on request) and EPOXY coated. Its robust design provides it with great rigidity, withstanding the most adverse operating conditions. Reinforced design is standard starting from DN 200.

EPOXY COATING:

The epoxy coating on all **ORBINOX** cast iron and carbon steel valve bodies and components is applied by means of an electrolytic process which provides the valves with a high resistance to corrosion and an excellent surface finish.

The **ORBINOX** standard colour is RAL-5015 blue.

GATE SAFETY PROTECTION:

In accordance with **EU Safety Standards (CE certified)**, **ORBINOX** automated valves are provided with metallic gate guards along the gate, thus preventing any body or object from being caught or dragged accidentally.



OTHER OPTIONS

Bottom splash guard (Fig.1 and 2):

There are two types of splash guard that can be installed within the lower part of the valve body. They permit the either periodic or continuous removal of solids that may accumulate during operation of the valve.

Open-closed lockout system (Fig.3):

The standard valve is ready to install a lockout pin for emergency or maintenance situations.

Other metallic materials:

Other materials may be used, such as carbon-steel, stainless steels (AISI 316, 317, 2.205...), special alloys (254SMO©, Hastelloys...) and Titanium.

Fabricated valves:

ORBINOX designs, manufactures and supplies special fabricated valves for special process conditions (great sizes and/or high pressures).

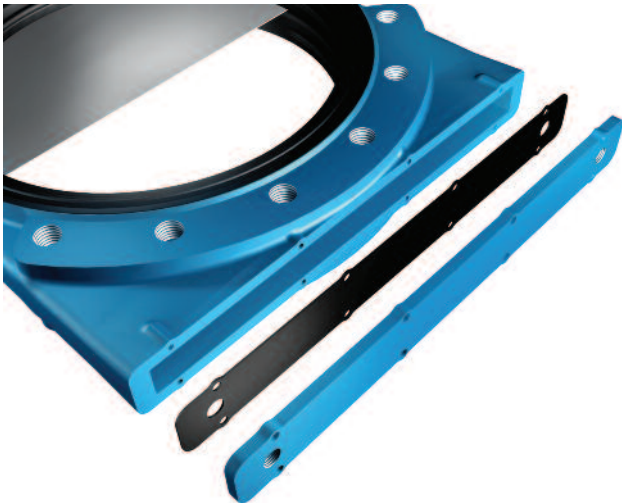

(Fig.1)



(Fig.2)

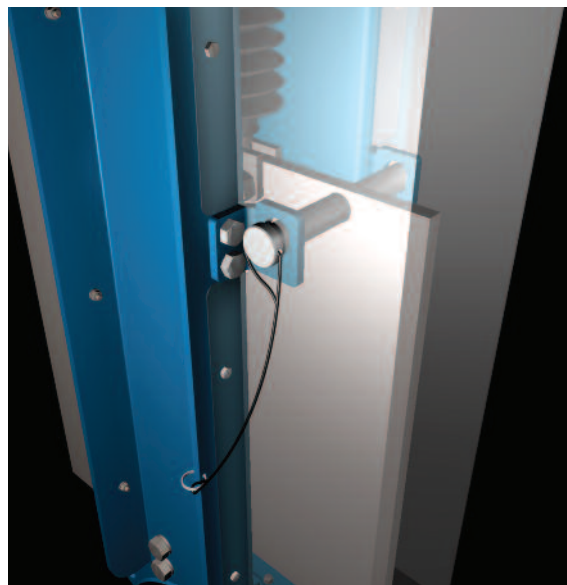

(Fig.3)

We recommend consultation with our technical department.

ACTUATOR TYPES

Manual:

Handwheel with rising stem
 Bevel Gear
 Others (on request)



Automatic:

Pneumatic cylinder
 Hydraulic cylinder
 Electric actuator



One of the design characteristics of ORBINOX S.A. valves is that **all actuators are interchangeable** with one another.

FAIL SAFE SYSTEMS

SINGLE ACTING FAIL-SAFE SYSTEMS

Used on pneumatic actuated valves, they allow the valve to remain in a predetermined position in case of failure (open/closed).

SINGLE ACTING / SPRING RETURN

Available from DN 50 to DN 200

Supply pressure: min. 6 kg/cm²

Options:

- Air opens (spring closes)
- Air closes (spring opens)

From DN 250 upwards an air reservoir is used.

SINGLE ACTING / VOLUME TANK

Available for all diameters.

- 1.- Pneumatic Fail-safe
- 2.- Pneumatic or Electric Fail-safe

GREAT VARIETY OF ACCESSORIES

- Open-closed lockout
 - Mechanical stops
 - Manual override actuators
 - Solenoid valves
 - Positioners
 - Limit switches
 - Proximity switches
 - Floor stands
 - ...
- to meet all needs

For further information, please see corresponding EX chapter.

We recommend consultation with our technical department.

TEMPERATURE CHART

SEAT / SLEEVES				PACKINGS	
Material	Min.T.(°C)	T.Max. (°C)	Applications	Material	Max. Temp. (°C)
Natural rubber	-30	75	General	EPDM	120
EPDM	-30	120	Acids and non mineral oils		
Neoprene	-30	90	Oils and solvents		
Chlorobutyl	-30	125	High temperatures		
Nitrile	-30	120	Hydrocarbons, oils and greases		

All of them are reinforced with a metallic core.
Other temperatures and applications consult with our technical department.

SEAT

RUBBER SLEEVES

The closure of the VG valve is achieved by its two characteristic high resistance elastomer sleeves, which improve the tight seal both in the adjustment with the flanges and in the closure. These sleeves have a metallic core which provides them with a great resistance to demanding working conditions and pressures.



OPEN



INTERMEDIATE



CLOSED

ATEX



Please contact our Orbinox representative for info and availability. Some considerations:

- Hand operated VG valves have been subjected to an ignition risk assessment according to DIN EN 13463: 1-5 and they are out the scope of application of ATEX Directive. Therefore hand operated valves are suitable for ALL ATEX zones.
- Electrical, pneumatical and hydraulically operated valves must be subjected to a conformity assesment of their own and also of the whole unit valve-actuator to get EC Type Approval to Directive 94/9.

HANDWHEEL (rising stem)

- Consists of:
 - Cast iron handwheel
 - Stem
 - Stem nut
- It is also equipped with a stem protector.
- Available from DN 50 to DN 600
 - Greater sizes on request
- Options (on request):
 - Open-closed lockout
 - PVC bellow
 - Extensions and floor stands

Note: use of the bevel gear is recommended for valve sizes greater than DN 200. Direct handwheel actuation is insufficient in these sizes for the maximum catalogue pressure.

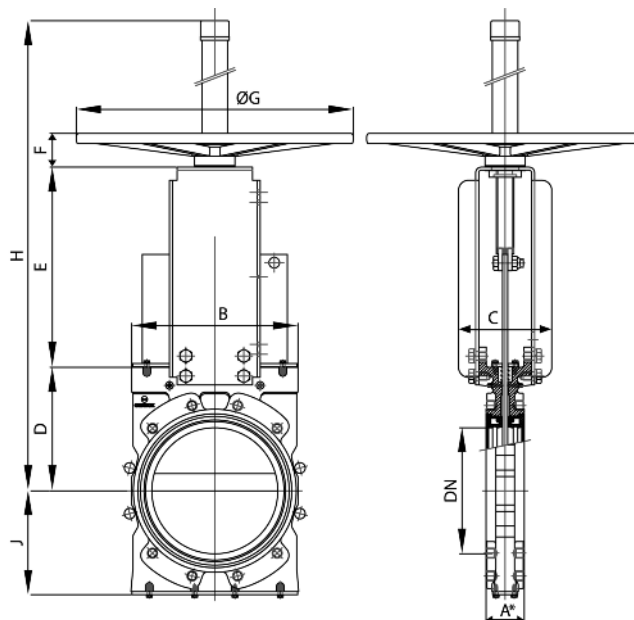

DN	A1*	A2*	B	C	D	E	F	ØG	H	J
50	54	60	140	100	105	145	47	225	440	63
80	57	63	175	100	124	175	47	225	545	90
100	57	63	170	100	140	200	67	310	620	100
125	63,5	69	195	100	150	240	67	310	700	123
150	63,5	69	230	100	175	265	67	310	755	130
200	76	83	280	165	205	325	66	410	935	160
250	76	83	335	185	245	415	66	550	1090	200
300	82,5	90	390	266	280	475	66	550	1260	232
350	82,5	90	440	270	325	555	66	550	1410	258
400	95	102	505	270	350	605	74	800	1677	292
450	95,5	103	560	270	420	680	74	800	1905	318
500	121	129	620	270	462	745	74	800	2020	345
600	121	129	730	270	510	845	74	800	2320	400

A1*: installed face to face
 A2*: minimum required dimension for installation

PNEUMATIC ACTUATOR

- The standard pneumatic actuator (double acting on-off cylinder) consists of:
 - Aluminium jacket and covers
 - Stainless Steel (AISI 304) piston rod
 - Nitrile coated steel piston
 - PVC bellows
- Available from DN 50 to DN 600
- Supply Pressure: 6 kg/cm²
- Reinforced design of support plates is standard starting from DN 200.
- Options (on request):
 - Hard anodized jacket and covers (stainless steel optional)
 - Open-closed lockout
 - Manual override actuator
 - Fail-safe systems
- Instrumentation (on request):
 - Positioners
 - Solenoid valves
 - Flow regulators
 - Air preparation unit

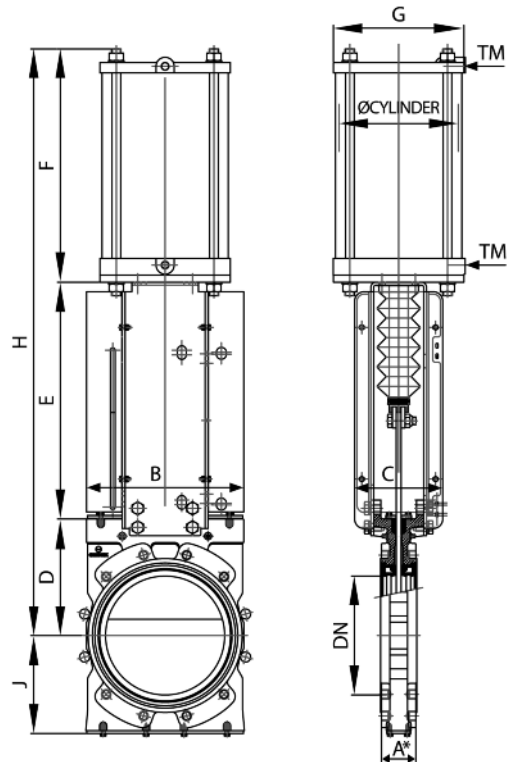

Note: in order to guarantee the correct functioning of the pneumatic cylinder for the catalogue pressures, a supply pressure of 6 bar is required. For lower pressures, we recommend consultation with our technical department.

DN	ØCYL.	TM (BSP)	A1*	A2*	B	C	D	E	F	G	H	J
50	C100/91	1/4"	54	60	140	100	105	145	220	100	470	63
80	C125/121	1/4"	57	63	175	100	124	175	260	140	559	90
100	C125/140	1/4"	57	63	170	100	140	198	280	140	618	100
125	C160/168	1/4"	63,5	69	195	100	150	240	320	175	710	123
150	C160/194	1/4"	63,5	69	230	100	175	265	345	175	785	130
200	C200/252	3/8"	76	83	280	165	205	322	420	220	947	160
250	C250/317	3/8"	76	83	335	185	245	415	505	277	1165	200
300	C300/376	1/2"	82,5	90	390	266	280	472	580	382	1332	232
350	C350/440	3/4"	82,5	90	440	270	325	555	710	444	1590	258
400	C350/490	3/4"	95	102	505	270	350	605	760	444	1715	292
450	C400/542	3/4"	95,5	103	560	270	420	677	830	515	1927	318
500	C400/606	3/4"	121	129	620	270	462	742	890	515	2094	345
600	C400/712	3/4"	121	129	730	270	510	843	1010	515	2363	400

A1*: installed face to face
 A2*: minimum required dimension for installation

BEVEL GEAR

- Recommended for valves larger than DN 200
- Consists of:
 - Stem
 - Yoke
 - Bevel Gear Actuator with Handwheel
- Available from DN 200 to DN 900
- Options: (on request)
 - Chainwheel
 - Open-closed lockout
 - Extensions and floor stands
 - PVC below

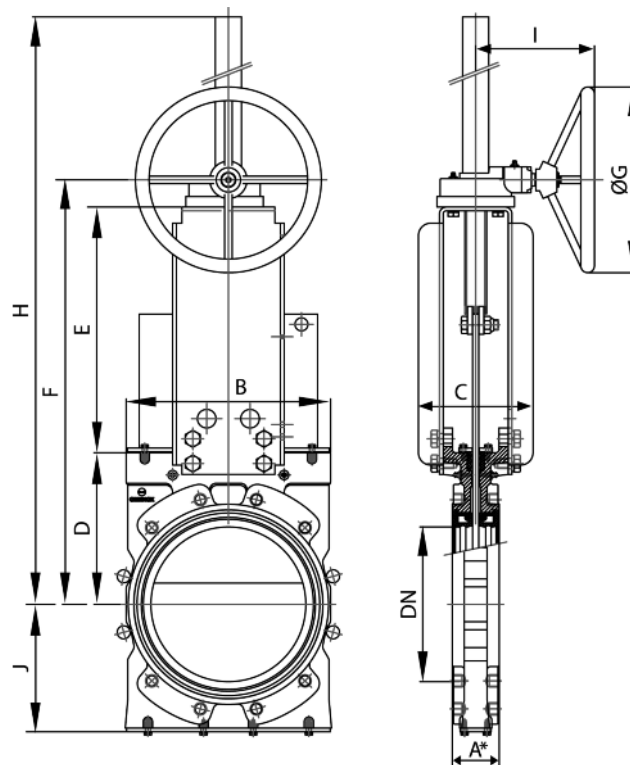

DN	BEVEL GEAR	A1*	A2*	B	C	D	E	F	Ø G	H	J	I
200	RKO.15	76	83	280	165	205	322	572	300	990	160	200
250	RKO.3	76	83	335	185	245	397	688	300	1510	200	263
300	RKO.3	82,5	90	390	250	280	441	767	450	1590	232	263
350	RKO.3	82,5	90	440	250	325	508	879	450	1700	258	263
400	RKO.3	95	102	505	270	350	567	963	450	1780	292	263
450	FL1.6	95,5	103	560	270	420	631	1155	450	2175	318	263
500	FL1.6	121	129	620	290	462	700	1265	650	2305	345	263
600	FL1.6	121	129	730	290	510	805	1420	650	2520	400	263
700	FL1.6	181	190	845	320	570	956	1628	650	2735	485	288
750	FL1.6	187	195	915	320	600	1021	1723	650	2780	510	288
800	FL1.6	206	214	980	320	650	1061	1833	650	2940	570	288
900	FL1.6	225,5	234	1074	320	700	1192	1995	650	3200	620	288

A1*: installed face to face
 A2*: minimum required dimension for installation

HYDRAULIC ACTUATOR

- The hydraulic actuator consists of a double acting cylinder in accordance with ISO 6020/2.
- Available from DN 50 to DN 900 with PVC bellows
- Hydraulic pressure: 100 bar
- Maximum hydraulic pressure: 160 bar
- Options:
 - Pressure indicators: mechanical and inductive.
 - Open-closed lockout
 - Position transducers
 - Hydraulic groups
 - Electrical cabinets

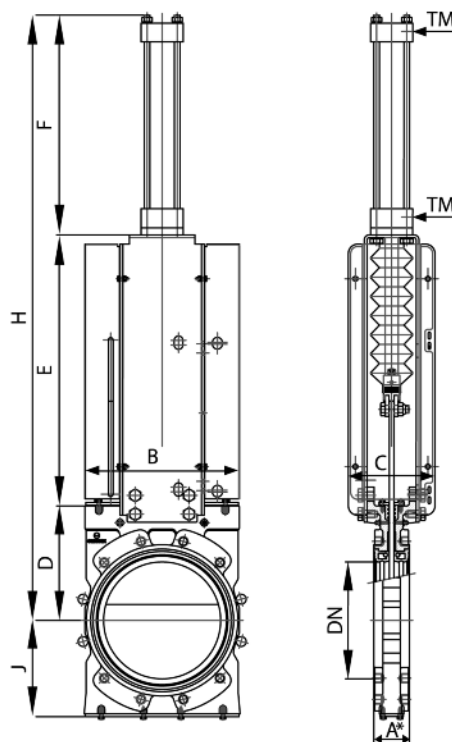

DN	Ø CYL.	TM (BSP)	A1*	A2*	B	C	D	E	F	H	J
50	C32/91	1/4"	54	60	140	100	105	260	205	570	63
80	C32/121	1/4"	57	63	175	100	124	283	230	637	90
100	C32/140	1/4"	57	63	170	100	140	305	248	693	100
125	C32/168	1/4"	63,5	69	195	100	150	350	306	806	123
150	C40/194	3/8"	63,5	69	230	100	175	370	338	883	130
200	C50/252	1/2"	76	83	280	165	205	427	405	1037	160
250	C63/317	1/2"	76	83	335	185	245	580	484	1309	200
300	C80/376	3/4"	82,5	90	390	266	280	639	543	1462	232
350	C80/440	3/4"	82,5	90	440	270	325	703	599	1627	258
400	C100/490	3/4"	95	102	505	270	350	779	649	1778	292
450	C100/542	3/4"	95,5	103	560	270	420	836	710	1966	318
500	C100/606	3/4"	121	129	620	270	462	952	774	2188	345
600	C125/712	1"	121	129	730	270	510	1175	909	2594	400
700	C100/825	3/4"	181	190	860	320	575	1224	1077	2876	490
750	C100/895	3/4"	187	195	930	320	605	1273	1109	2987	515
800	C125/950	1"	206	214	990	320	655	1443	1168	3266	565
900	C125/1060	1"	225,5	234	1095	320	705	1526	1335	3566	615

A1*: installed face to face

A2*: minimum required dimension for installation

ELECTRIC ACTUATOR

- Automatic actuator which consists of:
 - Electric motor
 - Rising stem
 - Motor support yoke flange
- The standard electric motor is equipped with:
 - Manual emergency handwheel
 - Limit switches (open/closed)
 - Torque switches (open/closed)
- Available from DN 50 to DN 900
- Wide range of types and brands available to meet customer requirements.
- Standardised flanges in accordance with ISO 5210/DIN 3338.
- Options: (on request)
 - Open-closed lockout

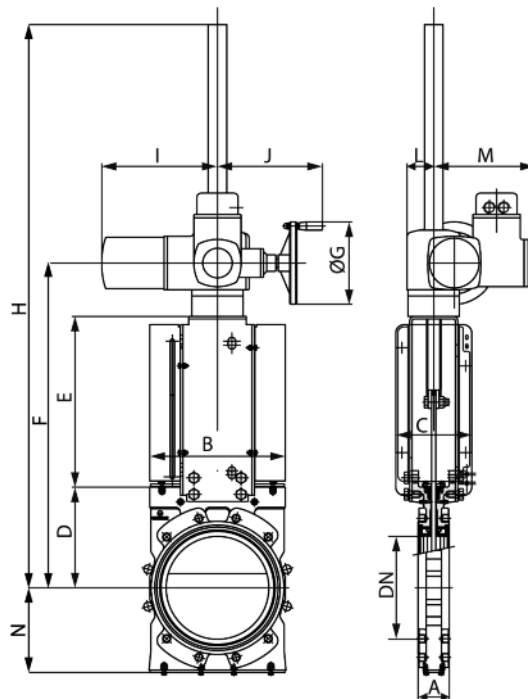

DN	A1*	A2*	B	C	D	E	F	ØG	H	I	J	L	M	N	TORQUE Nm
50	54	60	140	100	105	145	393	140	945	265	234	62	237	63	20
80	57	63	175	100	124	175	442	140	1000	265	234	62	237	90	20
100	57	63	170	100	140	198	481	160	1035	265	250	62	237	100	30
125	63,5	69	195	100	150	240	533	160	1085	265	250	62	237	123	35
150	63,5	69	230	100	175	265	583	160	1135	265	250	62	237	130	40
200	76	83	280	165	205	322	682	200	1245	282	256	65	247	150	50
250	76	83	335	185	245	415	790	200	1378	282	256	65	247	200	70
300	82,5	90	390	266	280	472	882	200	1470	282	256	65	247	232	110
350	82,5	90	440	270	325	555	1055	315	1657	385	325	90	285	258	120
400	95	102	505	270	350	605	1130	315	1732	385	325	90	285	292	160
450	95,5	103	560	270	420	677	1272	400	1974	385	332	90	285	318	200
500	121	129	620	270	462	742	1379	400	2481	385	332	90	285	345	300
600	121	129	730	270	510	843	1528	400	2630	385	332	90	285	400	350
700	181	190	860	320	575	980	1730	400	2832	385	332	90	285	490	450
750	187	195	930	320	605	1115	1930	500	3053	510	355	115	310	515	550
800	206	214	990	320	655	1220	2085	500	3208	510	355	115	310	565	600
900	225,5	234	1095	320	705	1370	2285	500	3408	510	355	115	310	615	750

A1*: installed face to face
A2*: minimum required dimension for installation

FLANGE AND BOLTING DETAILS

EN 1092-2 PN10

DN	K	n°	M	T	◆ ◆
50	125	4	M-16	10	4 - -
80	160	8	M-16	12	4 - 4
100	180	8	M-16	12	4 - 4
125	210	8	M-16	14	4 - 4
150	240	8	M-20	14	4 - 4
200	295	8	M-20	16	4 - 4
250	350	12	M-20	16	8 - 4
300	400	12	M-20	20	8 - 4
350	460	16	M-20	20	12 - 4
400	515	16	M-24	20	12 - 4
450	565	20	M-24	20	16 - 4
500	620	20	M-24	25	16 - 4
600	725	20	M-27	24	16 - 4

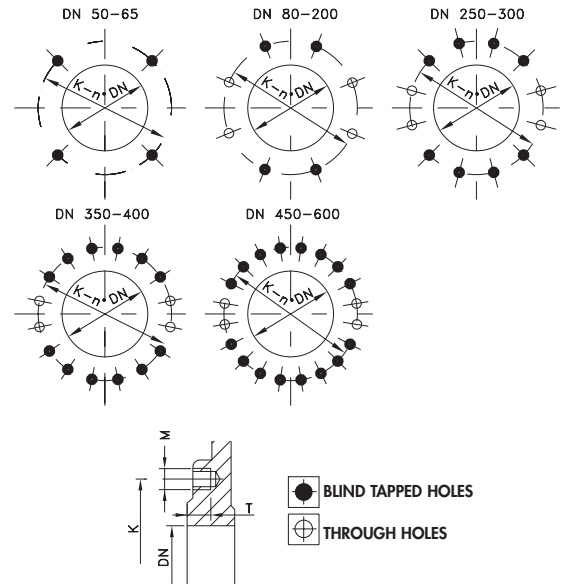

ANSI B16.5, class150

DN	K	n°	M	T	◆ ◆
2"	4 3/4"	4	5/8" UNC	3/8"	4 - -
3"	6"	4	5/8" UNC	1/2"	4 - -
4"	7 1/2"	8	5/8" UNC	1/2"	4 - 4
5"	8 1/2"	8	3/4" UNC	9/16"	4 - 4
6"	9 1/2"	8	3/4" UNC	9/16"	4 - 4
8"	11 3/4"	8	3/4" UNC	5/8"	4 - 4
10"	14 1/4"	12	7/8" UNC	5/8"	8 - 4
12"	17"	12	7/8" UNC	3/4"	8 - 4
14"	18 3/4"	12	1" UNC	3/4"	8 - 4
16"	21 1/4"	16	1" UNC	3/4"	12 - 4
18"	22 3/4"	16	1 1/8" UNC	3/4"	12 - 4
20"	25"	20	1 1/8" UNC	15/16"	16 - 4
24"	29 1/2"	20	1 1/4" UNC	15/16"	16 - 4

