



SwissValve Butterfly Valve Type CST

SwissValve Absperrklappe Typ CST



Product Information





Produktinformation

1. Product Characteristics

1. Produktmerkmale

1.1. Technical Characteristics

1.1. Technische Merkmale

Type CST	SwissValve Butterfly Valve with TFM Liner	SwissValve Absperrklappe mit TFM Ringbalg	Typ CST
Body Types	Wafer/Zwischenflanschmatur (W) 	Lug/Endarmatur (E) 	Gehäusebauformen
Scope of Application	Butterfly valve lined with TFM/PFA for high chemical demands. To shut off and control corrosive and abrasive liquids or gases.	TFM/PFA ausgekleidete Absperrklappe für hohe chemische Anforderungen. Absperren/Regeln von korrosiven bzw. aggressiven Flüssigkeiten und Gasen.	Anwendungsbereich
Face to Face Dimensions	According to ISO 5752, Basic Range 20; DIN EN 558-1, Basic Range 20	Gemäss ISO 5752, Grundreihe 20; DIN EN 558-1, Grundreihe 20	Einbaulänge
Head Flange	According to EN ISO 5211	Gemäss EN ISO 5211	Kopfflansch
Max. Operating Pressure	10 bar (DN040-600), 6 bar (DN 650-1050), Vacuum -0,1 bar	10 bar (DN040-600), 6 bar (DN 650-1050) bzw. bei Vakuum -0,1 bar	Max. Betriebsdruck
Connection Standards	PN10-16 (DN040-150), PN10 (DN 200-600), PN6 (DN 700-1050), ANSI CL150	PN10-16 (DN040-150), PN10 (DN 200-600), PN6 (DN 700-1050), ANSI CL150	Anschlussnormen
Temperature Range	-20°C up to +200°C (See Temperature-Pressure-Diagram on Page 2)	-20°C bis +200°C (Siehe Temperatur-Druck-Diagramm Seite 2)	Temperaturbereich
Identification Marking	EN 19	EN 19	Kennzeichnung
In-Shop Testing	<ul style="list-style-type: none"> Porosity Test of Disc Coating (PFA) and Liner (TFM) acc. to DIN EN 60243-1 Leakage Test acc. to EN 12266-1/P12 Leakage Rate A Check of Torque of each Valve acc. to internal Guidelines 	<ul style="list-style-type: none"> Porenprüfung der Scheibenbeschichtung (PFA) und Ringbalg (TFM) nach DIN EN 60243-1 Dichtheitstest nach DIN EN 12266-1/P12 Leckrate A Kontrolle des Drehmoments jeder Klappe nach internen Vorgaben 	Werksprüfung
TA-Luft	Compliance Leakage Certificate according to Position 5.2.6.4. of the Technical Instruction Air (TA-Air), VDI 2440	Erfüllung Leckagnachweis gemäss Ziffer 5.2.6.4 der Technischen Anleitung Luft (TA-Luft), VDI 2440	TA-Luft
	Compliance of the Safety Requirements of the European Pressure Equipment Directive 97/23/EG.	Erfüllung Sicherheitsanforderungen der Europäischen Druckgeräterichtlinie 97/23/EG.	
Atex	Atex compliant Version for explosive Surroundings Group II, Zones 0,1,2 (and 20, 21, 22 respectively)	Atex konforme Ausführung für explosionsgefährdete Bereiche der Gruppe II, Zonen 0, 1, 2 (bzw. 20, 21 und 22)	Atex



1.2. Technical Information

Pressure-Temperature-Diagram Druck-Temperatur-Diagramm

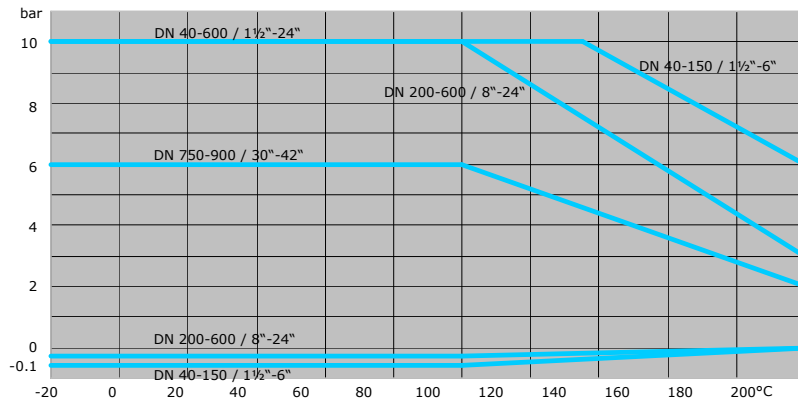

Liquid / Flüssigkeiten

$$Kv = Q \sqrt{\frac{\rho}{\Delta p}}$$

Gas / Gase

$$Kv = \frac{Q_n}{514} \sqrt{\frac{\rho_n \cdot T}{\Delta p \cdot p_2}}$$

Description	Symbol	Unit/Einheit	Beschreibung
Coefficient of Flow Rate	Kv	m ³ /h	Durchflusskoeffizient
Flow	Q	m ³ /h	Volumenstrom
Flow	Q _n	Nm ³ /h	Volumenstrom
Density	ρ	kg/dm ³	Dichte
Standard Density	ρ _n	kg/Nm ³	Normdichte
Outlet Pressure	P ₂	bar	Betriebsdruck nach Klappe
Pressure Drop	Δp	bar	Druckverlust
Operating Temperature	T	°K	Betriebstemperatur

1.3. Advantages of the TFM Liner

TFM is manufactured with PTFE and a 1% fraction of perfluoropropyl vinyl ether (PPVE). While the properties of conventional PTFE (excellent all-around chemical resistance, application in a wide service temperature range and extreme resistance to embrittlement or aging) will be conserved, the additive PPVE leads to a better allocation of the PTFE particles and thus to a higher density of the molecular structure. The following extra advantages are resulting:

	Advantages of TFM compared to ordinary PTFE	Vorteile von TFM zu herkömmlichem PTFE	
A.	Cold flow, measured as deformation under load, is significantly lower for TFM than for conventional PTFE: It is about the same value as conventional PTFE with 25% glass fibre.	Signifikant bessere Kaltflusseigenschaften (gemessen als Verformung unter Last): Gleiche Kaltflusseigenschaften wie PTFE mit 25% Glasfasern.	A.
B.	Reduced permeation leads to better barrier properties.	Verminderte Gasdurchlässigkeit bzw. erhöhte Sperreigenschaften.	B.
C.	The smooth surface provokes only a slight abrasion of the liner and less particles in the medium.	Die glatte Oberfläche provoziert geringeren Ringabrieb und weniger Abriebpartikel im Medium.	C.

1.2. Technische Daten

Flow Curve Regelcharakteristik

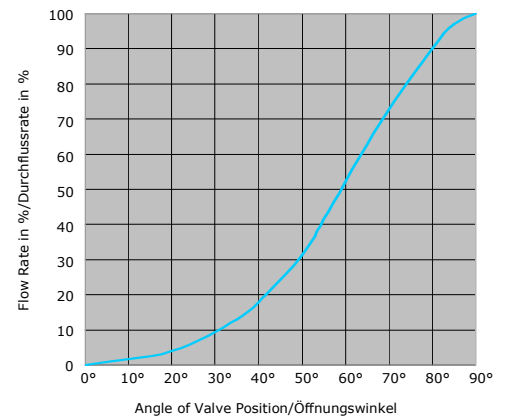

Flow Rate Kv in m³/h with Angle of Valve Position 90° Durchflusswerte Kv in m³/h bei Öffnungswinkel 90°

Inch	Kv	DN
1 1/2"	136	40
2"	193	50
2 1/2"	266	65
3"	392	80
4"	585	100
5"	1'015	125
6"	1'495	150
8"	3'050	200
10"	4'510	250
12"	6'500	300
14"	8'760	350
16"	11'350	400
18"	14'400	450
20"	18'000	500
24"	29'200	600
30"	54'400	
36"	81'016	900
42"	109'100	

1.3. Vorteile des TFM Ringbalgs

TFM wird aus herkömmlichem PTFE und einem 1% Anteil Perfluoropropyl Vinyl Ether (PPVE) gefertigt. Während die Eigenschaften von konventionellem PTFE (exzellente chemische Resistenz, Einsatz in grossem Temperaturbereich und versprödungs- bzw. alterungsarm, uvm.) gewahrt bleiben, führt der PPVE-Zusatz zu einer besseren Verteilung der PTFE-Partikel und somit insgesamt zu einer dichteren Polymerstruktur. Daraus resultieren folgende zusätzlichen Vorteile:

A. Permanent Deformation after Cyclic Load Bleibende Verformung nach wiederholter Belastung

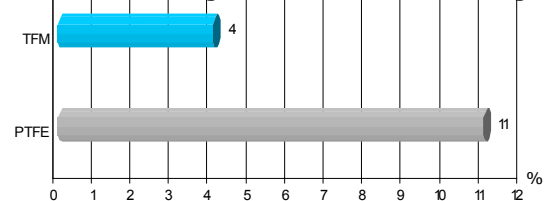

Load: 150 bar during 100 hours, Temperature 23°C
Permanent Deformation in %, 24 hrs after Load Removal
Belastung: 150 bar während 100 Std., Temperatur 23°C
Bleibende Verformung in %, 24 Std. nach Entlastung



**B. Permeability of Selected Chemicals
Gasdurchlässigkeit verschiedener Medien**

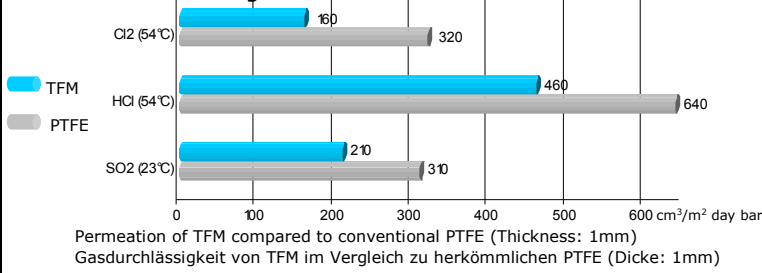

**C. Surface Property at 50x Magnification
Oberflächenbeschaffenheit in 50-facher Vergrößerung**

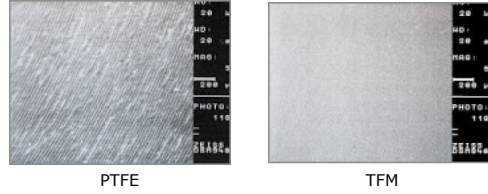

The advantages of TFM has a positive effect on the reliability of the installation and durability of the valve. Furthermore, downtimes and maintenance are minimised while the operating safety is increased.

Die Materialvorteile von TFM wirken sich bezüglich Zuverlässigkeit der Anlage und längerer Lebensdauer der Absperrklappen positiv aus. Gleichzeitig werden Stillstandzeiten und Wartungsaufwendungen minimiert und die Betriebssicherheit erhöht.

2. Parts List

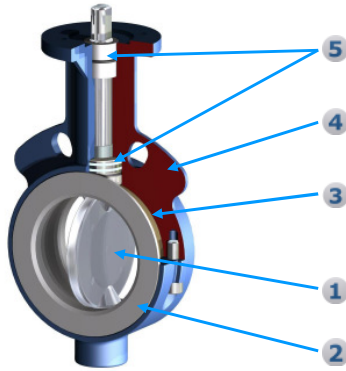

2. Stückliste

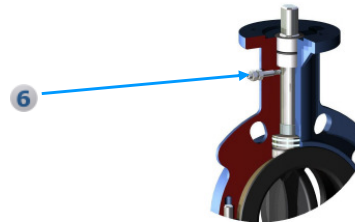

Position	Description	Bezeichnung	Position
1	Disc	Scheibe	1
2	Liner	Ringbalg	2
3	Back-Up	Einlage	3
4	Split Body	2-teiliges Gehäuse	4
5	Bearing and Pressure Packages	Lager- und Druckpakete	5
6	Atex Type*	Atex Ausführung*	6

3. Dimensions

3. Abmessungen

Wafer/Zwischenflanschmatur (W)

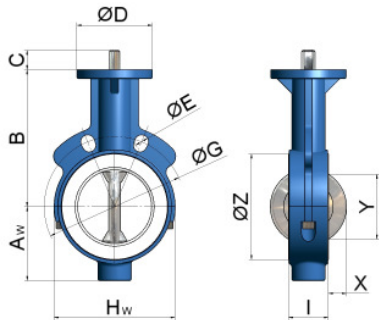

Lug/Endarmatur (E)

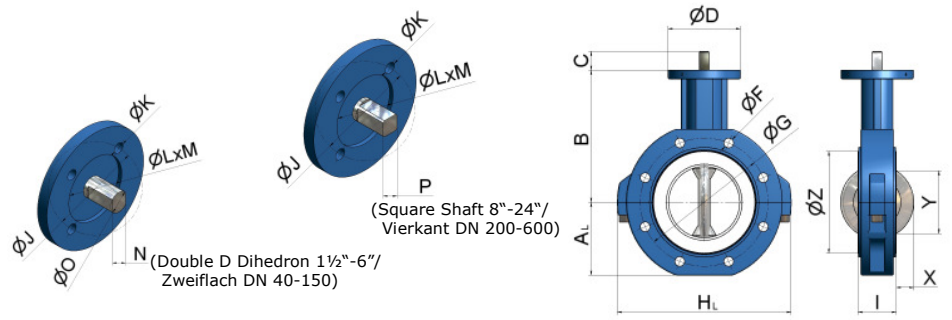

Inch ANSI	A _w	A _L	B	C	øD	øE DIN	øF DIN	øG DIN	øE ANSI	øF ANSI	øG ANSI	H _w	H _L	I	øJ	øK	øLxM	N	øO	P	X	Y	Z	ISO	kg _w	kg _L	DN DIN		
1½"	53*	53	94	19	65	4x18	4xM16	110	2x16	4x1/2"-13UNC	98.4	142*	142	33	50	4x7	36x3.5	9	13		7	34	76	F05	1.5	2.5	40		
2"	56	58	130	19	102	2x18	4xM16	125	2x19	4x5/8"-11UNC	120.6	104	153	43	70	4x9	56x3.5	11	14	Z	6	31	85	F07	3.0	5.0	50		
2½"	67	65	146	19	102	2x18	8xM16	145	2x19	4x5/8"-11UNC	139.7	128	173	46	70	4x9	56x3.5	11	14		11	48	106	F07	4.0	7.0	65		
3"	84	88	165	19	102	2x18	8xM16	160	2x19	4x5/8"-11UNC	152.4	144	210	46	70	4x9	56x3.5	11	14		17	63	122	F07	5.0	8.1	80		
4"	100	102	185	25	102	2x18	8xM16	180	2x19	8x5/8"-11UNC	190.5	164	245	52	70	4x9	56x3.5	14	18		27	90	143	F07	6.3	10.8	100		
5"	110	116	202	25	102	2x18	8xM16	210	2x22	8X3/4"-10UNC	215.9	194	272	56	70	4x9	56x3.5	14	18		38	118	166	F07	7.7	14.5	125		
6"	125	127	217	30	102	2x22	8xM20	240	2x22	8X3/4"-10UNC	241.3	220	295	56	70	4x9	56x3.5	17	22		47	137	193	F07	10.0	15.8	150		
8"	158	160	245	26	152	2x22	8xM20	295	2x22	8X3/4"-10UNC	298.4	274	364	60	102	4x11	71x3.5				24	19	71	189	251	F10	16.5	24.6	200
10"	190	193	270	30	152	2x22	12xM20	350	2x26	12x7/8"-9UNC	361.9	330	431	68	102	4x11	71x3.5				28	22	92	239	301	F10	24.5	33.3	250
12"	225	227	308	30	152	2x22	12xM20	400	2x26	12x7/8"-9UNC	431.8	380	511	78	102	4x11	71x3.5				28	22	112	290	349	F10	37.0	57	300
14"	256*	256	330	37	152	16x22	16xM20	460	12x29	12x1"-8UNC	476.2	571*	571	92	125	4x13	87x3.5				35	27	125	328	414	F12	87*	87	350
16"	292*	292	365	37	152	16x26	16xM24	515	16x29	16x1"-8UNC	539.7	643*	643	102	125	4x13	87x3.5				35	27	146	377	460	F12	107*	107	400
18"	311*	311	400	50	175	20x26	20xM24	565	16x32	16x1 1/8"-7UNC	577.8	684*	684	114	140	4x17	102x4.5				47	36	164	417	515	F14	152*	152	450
20"	340*	340	435	50	175	20x26	20xM24	620	20x32	20x1 1/8"-7UNC	635.0	745*	745	127	140	4x17	102x4.5				47	36	184	477	570	F14	185*	185	500
24"	398*	398	510	64	210	20x30	20xM27	725	20x35	20x1 1/4"-7UNC	749.3	863*	863	154	165	4x21	132x5.5				58	46	215	560	672	F16	254*	254	600
30"	482*	482	608	90	210				28x35	28x1 1/4"-7UNC	914.4	1040*	1040	154	165	4x21	132x5.5	**	**	**	70	**	289	716	851	F16	300*	300	
36"	573*	573	684	90	300	28x33	28xM30	1050	32x42	32x1 1/2"-6UNC	1085.8	1232*	1232	154	254	8x17	202x5.5	**	**	**	80	**	360	860	1016	F25	460*	460	900
42"	660*	660	768	90	300				36x42	36x1 1/2"-6UNC	1257.3	1402*	1402	154	254	8x17	202x5.5	**	**	**	80	**	434	1009	1170	F25	500*	500	

* = Body Type: Lug (E), Screw-in tap hole drilled through
** = Special Design

* = Gehäusebauform: Endarmatur (L), Gewindelöcher durchgebohrt
** = Spezialdesign



4. Add-ons

4.1. Hand Lever and Gearbox

Hand Lever Handhebel

Inches	C _h	W	kg	DN
1½"	46	230	0.8	040
2" - 3"	46	230	0.8	050 - 080
4" - 5"	55	270	1.1	100 - 125
6"	55	325	1.4	150
8"	55	349	1.9	200
10" - 12"	55	349	1.9	250 - 300

Gearbox Getriebe

Inches	C _g	Q	R	S	T	U	V	kg	DN
2" - 3"	64	138	125	84	67.5	43.5	45.7	2.0	050 - 080
4" - 5"	64	144	160	84	67.5	43.5	45.7	2.0	100 - 125
6"	75	201	160	112	81.5	52.5	55	3.9	150
8"	75	203	200	112	81.5	52.5	55	3.9	200
10"	75	203	200	112	81.5	52.5	55	3.9	250
12"	91	261	250	135	115	68.8	72.5	7.7	300
14" - 16"	91	266	315	135	115	68.8	72.5	7.7	350 - 400
18" - 20"	87	204	315	138	105	71	83	9.0	450 - 500
24"	90	227	315	200	126	86	101	14.5	600

Form	Part	Material	Werkstoff	Bauteil	Art
Hand Lever	Handhold	St. Steel	Edelstahl	Griff	Handhebel
	Notched Plate	St. Steel	Edelstahl	Rasterscheibe	
Gearbox	Gearbox Casing	GG 25 / Epoxy	GG 25 / Epoxy	Getriebegehäuse	Getriebe
	Shaft	St. Steel	Edelstahl	Welle	
	Handwheel	Steel / Epoxy	Stahl / Epoxy	Handrad	

4. Zusatzmaterial

4.1. Handhebel und Getriebe

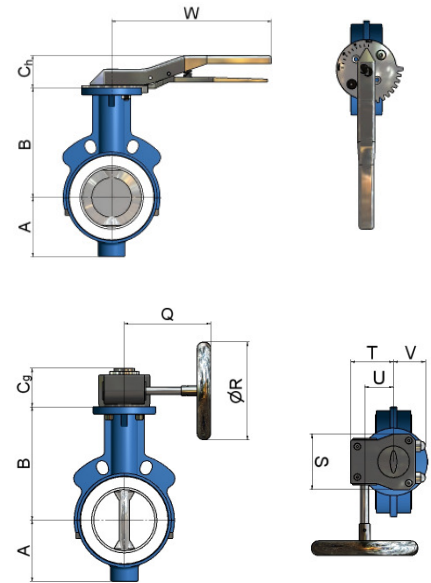

4.2. Torque for Actuators

DN	040	050	065	080	100	125	150	200	250	300	350	400	450	500	600	900	DN		
Inches	1½"	2"	2½"	3"	4"	5"	6"	8"	10"	12"	14"	16"	18"	20"	24"	30"	36"	42"	Inches
Initial Breakaway Torque (NM)	15	30	35	45	60	80	110	190	300	400	450	500	600	650	750	2000	2700	3600	Losbrechmoment (NM)
Max. allowable Torque Shaft (NM)	25	61	61	61	179	179	309	309	604	604	1200	1600	1950	2400	3200	8000	12000	12000	Max. zul. Drehmomente Welle (NM)

4.2. Drehmomente für Antriebe

The indicated initial breakaway torque includes 10% security.

Die angegebenen Losbrechmomente beinhalten 10% Sicherheit.

5. Coding

The **SwissValve** Butterfly Valve **CST** is based on the scheme of concentric and soft sealing valves. The construction enables any possible combination of disc, liner and body. Disc and shaft are one-piece. Different models and qualities of body and liner are available.

5. Typenschlüssel

Die **SwissValve** Absperrklappe **CST** ist auf dem Prinzip der konzentrischen, weichdichtenden Ventile aufgebaut. Das Konstruktionssystem ermöglicht eine beliebige Kombination von Scheibe, Ringbalg und Gehäuse. Scheibe und Welle sind einteilig, Gehäuse und Ringbalg sind in verschiedenen Ausführungen und in verschiedenen Qualitäten lieferbar.

Disc/Scheibe	Liner/Ringbalg	Back-Up/Einlage	Body/Gehäuse	Body Type/Bauform	Standard-Flange/Norm-Flansch
P - PFA	T - TFM(PTFE)	S - Silicone/Silikon	G - 0.7043 (GGG-40.3)/Epoxy	W - Wafer/Zwischenflansch	D1 - DIN PN10
C - PFAC cond.	C - TFM cond.	V - Viton	S - St.Steel/Edelstahl**	E - Lug/Endklappe	D2 - DIN PN16
S - St. Steel/Edelstahl*	F - TFM cond.FDA	E - EPDM	C - C-Steel/C-Stahl		A1 - ANSI 150 lbs
F - Polished St. Steel/Edelstahl poliert	U - UHMPE	F - Viton FDA			J1 - JIS 10K
T - Titanium/Titan Grade/Grad 2					AD - AS-2129 Table D
H - Hastelloy C22					AE - AS-2129 Table E
					SA - SANS 1123-1000/3

* 1.4404, 1.4408, 1.4409, 1.4581

** 1.4301

Ordering Example/Bestellbeispiel: **CSTPTSG100WA1-WD1-WD2**

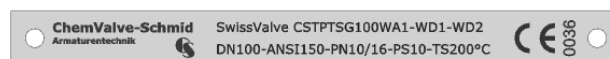

SwissValve Butterfly Valve **CST** DN100/SwissValve Absperrklappe **CST** DN100

Type/Typ	Disc/Scheibe	Liner/Ringbalg	Back-Up/Einlage	Body/Gehäuse	DN	Body Type/Bauform	Standard and Flange/Norm und Flansch
CST	P	T	S	G	100	W	A1 - D1 - D2
	PFA	TFM	Silicone/Silikon	0.7073(GGG40.3)Epoxy		Wafer/Zwischenflansch	ANSI 150 and/und DIN PN 10/16