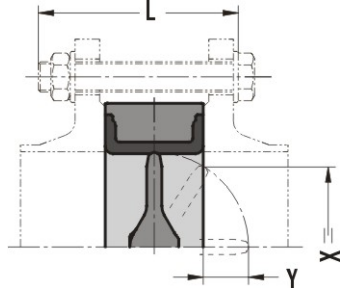
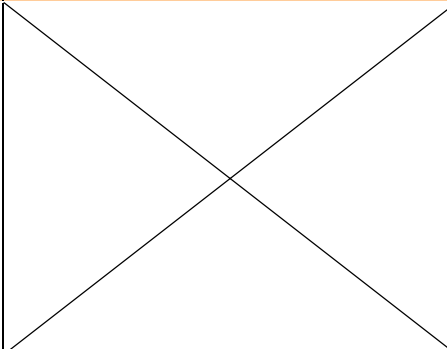

TYPE EVS	IN LINE INSTALLATION	DEAD END SERVICE
		

SIZE		DISC PROTRUSION		FLANGE THICKNESS			BOLTING LENGTH (L)		
DN	NPS	X	Y	EN 1092 PN 10	EN 1092 PN 16	ASME B16.5 CL 150	PN 10	PN 16	CL 150
50	2"	25	4	18	18	19.1	100	100	4¼"
65	2½"	46	10	18	18	22.4	110	110	4½"
80	3"	66	17	20	20	23.9	110	110	4¾"
100	4"	86	24	20	20	23.9	120	120	5"
125	5"	112	35	22	22	23.9	130	130	5¼"
150	6"	140	47	22	22	25.4	130	130	5½"
200	8"	191	70	24	24	28.5	140	140	5¾"
250	10"	241	91	26	26	30.3	150	150	6½"
300	12"	290	111	26	28	31.8	160	180	7"
350	14"	327	129	26	30	35.1	160	180	7½"
400	16"	373	142	26	32	36.6	200	220	8½"
450	18"	421	161	28	40	39.7	220	240	9½"
500	20"	470	180	28	44	43.0	220	260	10"
600	24"	566	216	28	54	47.8	260	320	11½"
700	28"	666	261	30	36	-	260	280/95	-
750	30"	711	278	-	-	-	-	-	-
800	32"	763	298	32	38	-	300	320	-
900	36"	863	342	34	40	-	320/90	340/100	-
1000	40"	973	390	34	42	-	340/90	360/100	-
1200	48"	1159	466	38	48	-	380/90	420/110	-
1400	56"	1364	568	42	52	-	400/105	-	-

Note: Where 2 length dimensions are given, the short one is not-through bolting at the shaft passages (8 bolts/valve).

FLANGE BOLTING LENGTH

The minimum bolting length of a wafer type valve between flanges with through bolting can be calculated with the formula:

$$L_{MIN} = 1 \times F_{toF} + 2 \times \text{Flange Thickness} + 1 \times H_{NUT} + 2 \times H_{SPACER} + 1 \times \text{pitch thread}$$

The table shows the calculated bolt lengths for ISO PN and ASME flanges, based on the following assumptions:

- flange thickness of a steel welding neck flange according EN 1092 and ASME B16.5;
- use of hexagon head cap screws, two spacers and a nut;
- standard available bolt lengths.

Important: Only as guideline, any deviation requires recalculation of the bolt length.